

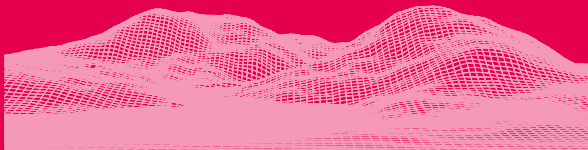

SONIC  
MEGA 8K



**Dear User,**

Thank you for joining us. Please read the Sonic Mega 8K manual thoroughly and follow the instructions step by step to get the best printing experience.

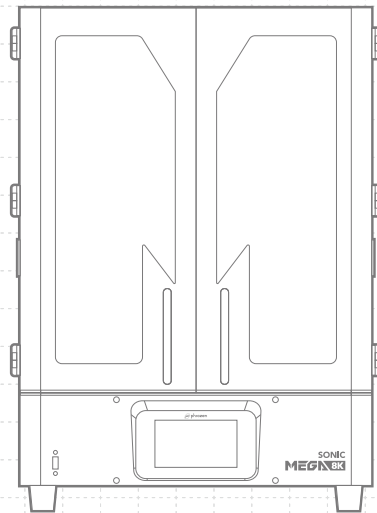

# 01 Introduction

## Printer Parts

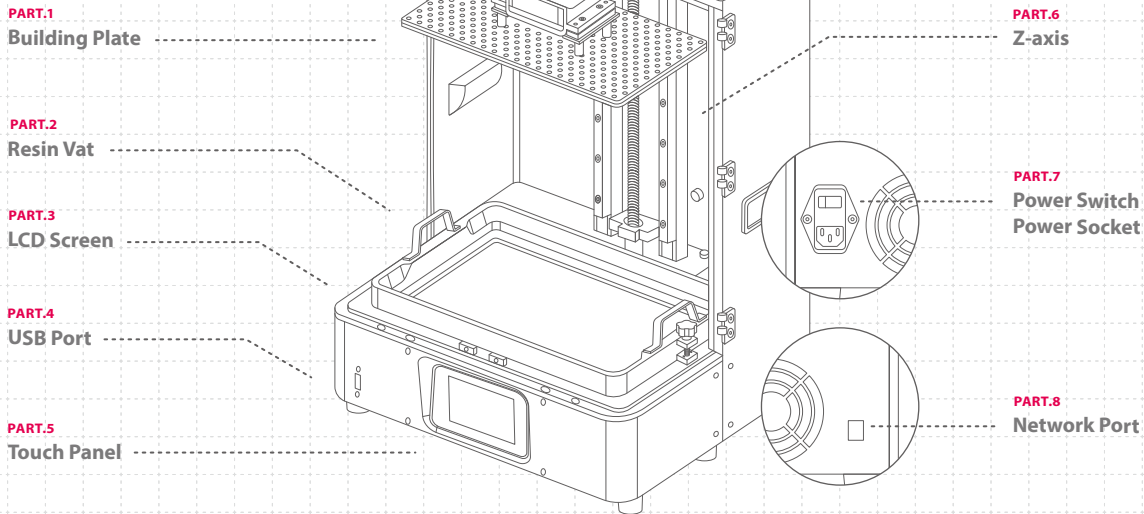

## The Toolbox



After Sales Service Card



Gloves



Power Connector



Plastic Funnel



Scrapers



Allen Wrench



USB



Handles

## Operation

System	Phrozen OS
Operation	5 inch Touch Panel
Slicer Software	CHITUBOX V1.9.0 or above
Connectivity	Front USB Port   Ethernet

## Printing Specifications

Technology	Resin 3D Printer - LCD Type
Light Source	405nm ParaLED® Matrix 3.0
XY Resolution	0.043 mm
Layer Thickness	0.01-0.30 mm
Max Printing Speed	70 mm / hr
Power Requirement	100-240V AC ; 50-60Hz

## Hardware Specifications

Printer Size	L47 x W40 x H68 cm
Printing Volume	L33 x W18.5 x H40 cm
Printer Weight	35 kg

\* All specifications have been tested in a laboratory. Please note that certain specifications may be subject to change without prior notice.

## 02 Key Notes Before Start

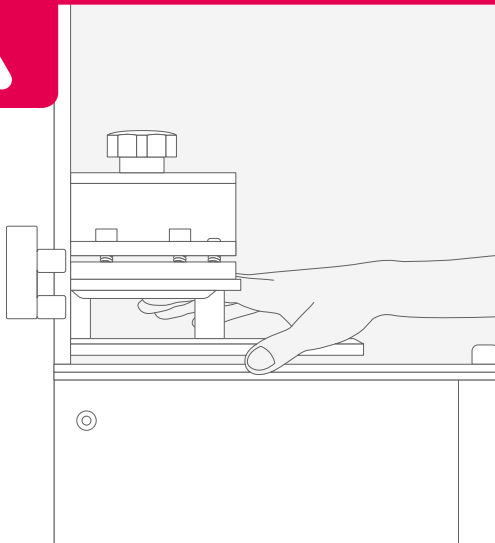

### **DO NOT Calibrate the Z-axis or Disassemble the 3D Printer.**

Sonic Mega 8K comes with a pre-calibrated building plate. Please **DO NOT** calibrate the Z-axis or disassemble the 3D printer on your own, as this may damage the 3D printer and cause your warranty to become invalid.

In order to prevent damage against the LCD screen, please **DO NOT** install a screen protector **NOR** switch building plates with any other 3D printers as it may cause calibration failure.

-----  
If you have any technical questions, please scan the QR codes to contact us.



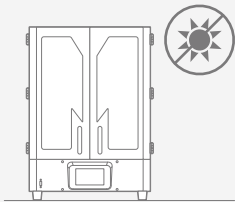

### Stable Printing Environment

Store your 3D printer in a dry and ventilated environment. Avoid exposure to direct sunlight. Make sure to place it on a flat surface.

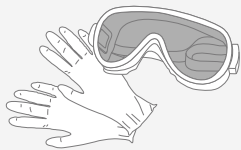

### Protective Measures

While printing and using resin, please make sure to wear gloves, masks, protective goggles, and long-sleeved clothing.

### Maintenance

#### Clean the Z-axis

First, dry clean the Z-axis T-screw. Then apply a thin layer of general lubricant on it, so that it whirls smoothly.

#### Clean the 3D Printer

Use sanitizing alcohol and tissue paper to carefully clean the printer, the resin vat, and the building plate.

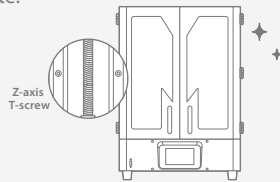

## 03 Prepare Your 3D Printer

For first-time use, please thoroughly follow the steps down below to conduct the LCD Test so that your 3D printer is ready to print.

### LCD Test

- 1 Click on TOOLS. Then click on LCD TEST.
- 2 Check to see if the LCD screen displays the same image as seen on the touch panel.
- 3 When the LCD screen clearly displays the image, the LCD TEST is complete.



\* Please refer to the actual operation situation based on the printer display.

## 04 Import Your 3D File

After preparing your 3D print files, there are 2 ways to import your files onto the Sonic Mega 8K: via Ethernet or USB.

### Prepare Your 3D File

- 1 On your computer, import the STL file to CHITUBOX V1.9.0 or above.
- 2 Click settings to add a new printer "Sonic Mega 8K." Set your Print Parameters according to the resin you will use.
- 3 Slice the 3D file and save it as CTB file, before importing it to your 3D printer.



Download Slicer



Resin Profile

Please refer to the resin profile for the updated printing parameters and use the XP\_Finder in the USB to find the optimal printing parameters.

## Importing via Ethernet

- 1 Insert the USB and connect your printer to the same router as your computer.
- 2 Click on **TOOLS**, and select **NETWORK** to check the IP address of the 3D printer.



\* The IP address in the following photo is for reference only.

- 3 Operate CHITUBOX on your computer. After slicing your 3D file, click on "Network Sending" to send you file to the printer.

- 4 Make sure to select CHITUBOX slicer(\*.ctb) as your file type before sending it over to your 3D printer's IP address.
- 5 After successfully sending over your file, click on "OK" to start printing immediately.
- 6 If not, click on "Cancel", the file will directly be stored onto the USB drive plugged onto your printer.

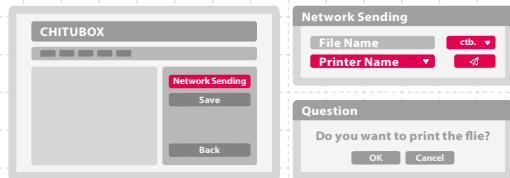

## 05 Perform the Printing Test

### Printing Test

- 1 Use both hands to tighten the screws and fasten the resin vat at the same time.
- 2 Make sure that both the resin vat and the building plate are parallel to the printer. The surface should be clean. Shake the resin bottle for 1 minute. When pouring, make sure the resin does not exceed the mark on the resin vat.
- 3 Import your ctb. file into Sonic Mega 8K. Then select the file and click GO to begin printing.
- 4

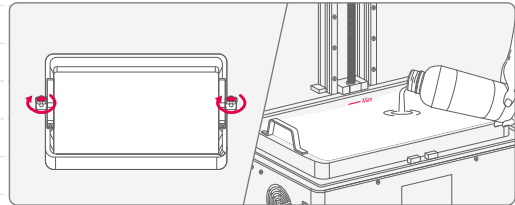

### Importing via USB

- 1 Save the CTB file in the USB and insert it into the 3D printer.
- 2 Click on PRINT and choose your file to begin printing.





- 5 While printing, please keep the chamber closed to prevent the 3D prints from distorting in shape.
- 6 Once printing is complete, please use both your hands and carefully remove the building plate to prevent damage against the LCD screen.
- 7 Tilt and place the building plate onto a desk and use a metal scraper to carefully remove your print.
- 8 Use 95% sanitizing alcohol or Phrozen Wash Resin Cleaner to rinse your printed model. Then cure your models with a Post-Curing Chamber, After curing, your first print is complete.

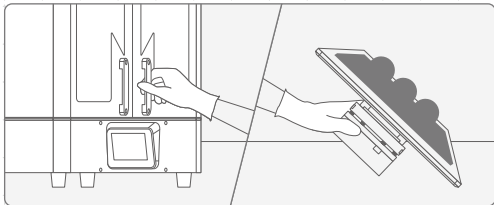

## After-sales service & warranty

- Phrozen offers a one-year warranty for all parts, excluding consumable components such as the LCD screen and FEP film.
- Sonic Mega 8K LCD screen is covered under a 3-month warranty. Please note that this warranty does not cover any damages caused by human factors.
- If you encounter any difficulties, please scan the QR codes down below to contact us.

Contact us!



# Congratulations!

You have just completed your first run.  
We hope you've had a great experience!

Please follow Phrozen's social media accounts  
and subscribe to our YouTube channel to learn  
more about printing tips and share information  
with the community.



**Facebook**



**Facebook Group**  
Sonic Mega 8K



**YouTube**



**Instagram**





SONIC  
MEGA 8K

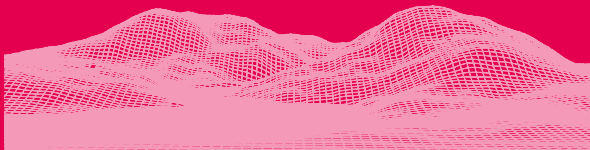

親愛的使用者您好，

非常開心您的加入，為了您良好的使用經驗，請您務必詳閱 Sonic Mega 8K 說明書進行產品測試及列印。

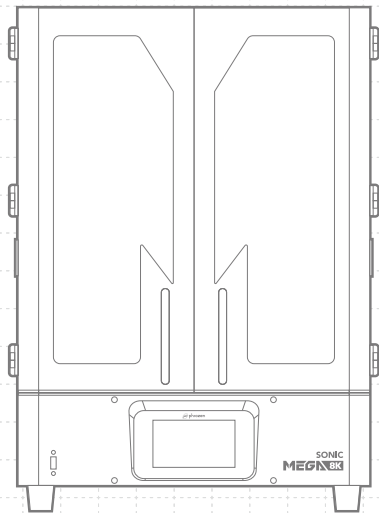

# 01 產品介紹

## 機台構造說明

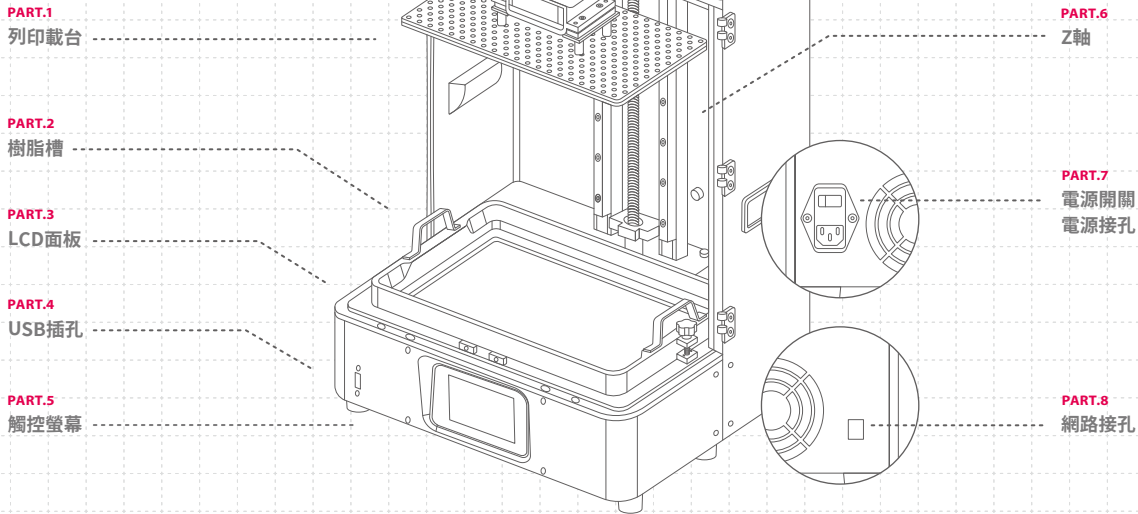

## 配件盒內容物



客服保固卡



手套



電源線



塑膠漏斗



軟硬刮刀



六角板手



USB



機門把手組

## 操作系統

機台系統	Phrozen OS系統
操作介面	5吋 IPS觸控面板
切層軟體	CHITUBOX V1.9.0 或以上
檔案傳輸模式	前置USB插孔   乙太網路

## 技術規格

技術規格	LCD光固化
光源設計	405nm ParaLED® Matrix 3.0
XY 解析度	0.043 mm
切層厚度	0.01-0.30 mm
最快列印速度	70 mm / 小時
適用電壓	100-240V AC ; 50-60Hz

## 硬體規格

機台尺寸	長47 x 寬40 x 高68 公分
列印尺寸	長33 x 寬18.5 x 高40 公分
機台重量	35 公斤

\* 以上為實驗測試數據，若有內容更改恕不另行通知。

## 02 使用前注意事項

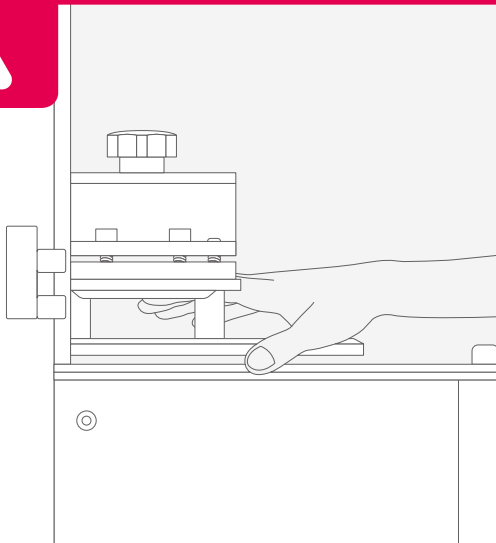

### 請勿校正Z軸與拆卸列印機

本產品為預校正Z軸設計，請勿自行進行Z軸校正與拆卸列印機，以免造成產品損壞與保固失效；自行加裝LCD保護貼，或使用其他機台的列印載台，將會造成校正失效以及LCD破裂。

如有列印相關問題請掃描  
QRcode聯絡我們



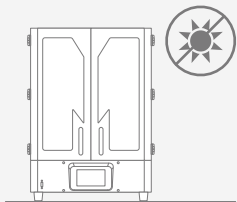

### 列印環境

請將3D列印機置於室內乾燥通風處之水平桌面，並避免陽光直射與高溫曝曬。

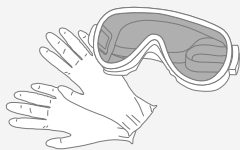

### 保護措施

進行列印時，請佩戴手套、口罩、護目鏡、長袖衣物等個人防護設備。

### 機台保養

#### Z軸清潔

擦乾Z軸螺桿後，請使用少量一般潤滑油，潤滑Z軸螺桿使其運行更順暢。

#### 機台清潔

可使用消毒酒精與紙巾小心擦拭機台、樹脂槽與列印載台。

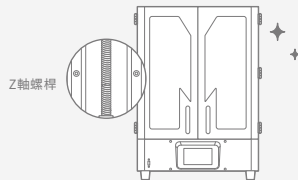

## 03 準備您的3D列印機

初次使用請依下列步驟設置您的3D列印機，首先請執行LCD測試。

### LCD 測試

- 1 點選「TOOLS」，然後點選「LCD TEST」。
- 2 確認LCD面板發光區域與觸控面板顯示圖像相同。
- 3 當LCD面板完整顯示圖像時，即完成LCD測試。

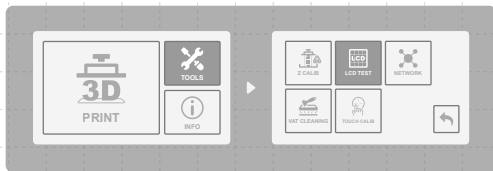

\* 實際操情形請依機台顯示為主。

## 04 檔案傳輸

在準備3D列印檔之後，Sonic Mega 8K 提供兩種方式傳輸檔案，使用乙太網路或USB傳輸。

### 準備3D列印檔

- 1 在電腦中，將您的STL檔放入切層軟體CHITUBOX (V1.9.0版本或後續更新版)。
- 2 選擇新增「Sonic Mega 8K」列印機，並依照您使用的樹脂設定列印參數。
- 3 設定完成，請將3D檔案進行切層存為CTB檔並放入USB。
- 4 檔案準備即完成。



切層軟體下載



樹脂參數

推薦您參考線上的樹脂參數，我們將隨時新增或調整更適合的設定，並使用USB中的XP\_finder找到更適合您的列印參數。



## 透過乙太網路傳輸檔案

- 1 將列印機插上USB與網路線，並將列印機及電腦連線到相同網路。
- 2 進入TOOLS，點選NETWORK螢幕顯示此列印機的IP。



\* 上圖IP碼僅供參考。

- 3 在CHITUBOX軟體切層完檔案後，點擊「網路發送」。

- 4 選擇 CHITUBOX slicer(\*.ctb) 檔案規格，並將檔案傳送到列印機的IP。
- 5 傳輸完成後，點擊「是」可以立即開始列印。
- 6 無需立即列印請點選「取消」，檔案會儲存在機台上的USB中。

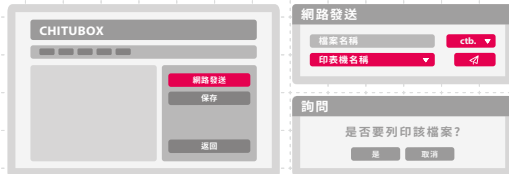

## 05 執行列印測試

### 列印測試

- 1 雙手需同時轉緊樹脂槽兩側螺絲。
- 2 確保樹脂槽與列印載台兩者水平固定於機台且乾淨無異物。
- 3 上下搖動樹脂瓶1分鐘，使其均勻後再倒入樹脂槽內，填充量不可高於槽內的刻度。
- 4 將CTB檔輸入Sonic Mega 8K。接著選擇檔案並點選「GO」開始列印。
- 5 列印中請關上遮光門板，以免其他光源干擾影響模型成形。

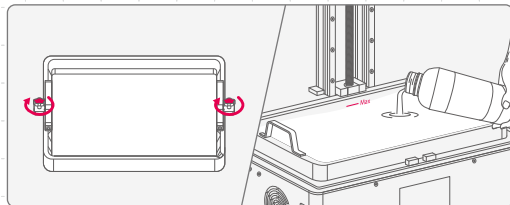

### 透過USB傳輸檔案

- 1 將切層後的CTB檔儲存至USB並插入列印機。
- 2 點選觸控螢幕的PRINT，接著點選檔案即可開始列印。



- 待列印完成後，請用雙手小心將列印載台取下，以避免碰撞LCD造成破裂。
- 將載台從列印機上移至桌面。將列印載台斜靠於桌面，一手固定並小心使用金屬刮刀將列印成品從載台上取下。
- 使用95%的酒精或 Phrozen Wash 等清洗劑清洗模型，最後再使用固化燈固化模型，列印測試即完成。

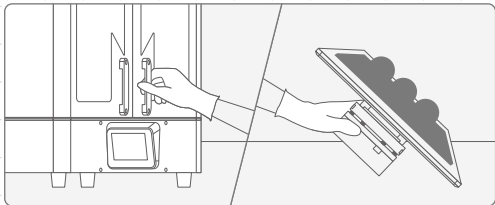

## 產品保固與售後服務

- Phrozen機台提供1年非人為損壞保固，列印耗材LCD面板與FEP膜除外。
- Sonic Mega 8K 的 LCD 面板提供3個月非人為損壞保固。
- 若使用上遇到任何問題，請掃描下方QRcode，聯絡 Phrozen 團隊。

Phrozen  
客服團隊



## 恭喜

恭喜您完成初步操作流程，感謝您的支持並期望您有良好的使用體驗。

歡迎關注Phrozen的社群帳號，並訂閱我們的 Youtube Channel 學習更多關於列印的技巧並分享您的列印經驗。



Facebook



Facebook  
台灣站社團



YouTube



Instagram